

## COMPRESSED BREATHING AIR

### I. INTRODUCTION

A. Atmosphere supplying respirators, including self contained breathing apparatus (SCBA) and supplied-air (airline) respirators are the most complex types of respirators and require detailed respirator programs to support their use. One of most important elements of these respirator programs are procedures to ensure atmosphere supplying respirators provide high quality breathing air to the wearer.

B. There are several standards, regulations, and instructions, discussed in Section II, that establish breathing air quality requirements and govern the use of atmosphere supplying respirators.

### II. BREATHING AIR QUALITY STANDARDS

#### A. 29 CFR 1910.134

1. The Occupational Safety and Health Administration (OSHA) in paragraph (c)(1)(vi) of reference (1), [\*OSHA Respirator Standard\*](#), requires procedures to ensure adequate quality, quantity, and flow of breathing air for atmosphere-supplying respirators. Paragraph (i) requires that compressed and liquid oxygen shall meet the United States Pharmacopoeia requirements for medical or breathing oxygen and compressed breathing air shall meet at least the requirements for Grade D breathing air described in *Compressed Gas Association Commodity Specification for Air, G-7.1-1989 [2004]*.

2. Paragraph (i)(4)(ii) requires that cylinders of purchased breathing air have a certificate of analysis from the supplier stating that the breathing air meets the requirements for Grade D breathing air. There are also specific low moisture content requirements.

#### B. OPNAVINST 5100.23 Series

1. Paragraph 1506 of [\*OPNAVINST 5100.23 Series\*](#), reference (2) states that breathing air must meet at least the 29 CFR 1910.134 requirements for grade D air established in *CGA G-7.1-2004*. Paragraph 1506.b. states that "*Activities shall conduct monitoring of the breathing air quality at least quarterly.*"

a. The NOTE to this paragraph states, "*Monitoring does not apply to ambient air breathing apparatuses.*" According to reference (3), AABA do not require carbon monoxide monitors and alarms or periodic monitoring for air quality, however the air intake must be located in an area free of contaminants.

b. It was recommended during reference (3) that permanently installed non-oil-lubricated (oil-less) compressors be equipped with carbon monoxide monitor and alarm systems.

2. Paragraph 1506.(c) of reference (2) requires that newly purchased compressors (except AABA) must be equipped with continuous carbon monoxide monitor and alarm systems. Existing compressors must have continuous carbon monoxide monitor and alarm systems installed when they are upgraded during major overhaul maintenance. This paragraph also requires that carbon monoxide monitor and alarm

systems be calibrated according to manufacturers' instructions. More information on this issue is provided in *Section VI. Standard Specific Compressor Requirements*.

C. OPNAVINST 5100.19 Series

1. Paragraph B0611 of [OPNAVINST 5100.19 Series](#), reference (4) requires testing breathing air compressors quarterly to ensure grade D air quality as defined in *CGA G-7.1-2004, Commodity Specification for Air*. Like paragraph 1506, paragraph B0611 has carbon monoxide monitor and alarm requirements, which are discussed in *Section VI. Standard Specific Compressor Requirements*.

- a. Ship's LP air is not suitable for use as breathing air unless specifically tested and certified to meet Grade D Air criteria.
- b. Ambient air breathing apparatus air quality testing is not required.

D. CGA G-7.1

1. Brief History of CGA G-7.1. The Compressed Gas Association, Inc. published the sixth edition of CGA G-7.1 on 13 October 2011. ANSI jointly published the first three editions (1966, 1973, and 1989) of this standard as ANSI Z86.1. However, the 2011, 2004 or the 1997 editions were published solely by CGA.

- a. CGA G-7.1-1989 edition changes from 1973 edition:
  - i. Grades B, C, F, and H gaseous air were discontinued because they no longer had major usage in industry.
  - ii. Type II - Grade B liquid air was discontinued.
  - iii. Established four new gaseous air classes - K, L, M, and N.
  - iv. Reduced the maximum allowable concentration of carbon monoxide in Grade D air from 20 ppm to 10 ppm.
- b. The CGA G-7.1-1997 standard discontinued three quality verification levels (Grades) from the 1989 edition, which included Grades K, G, and M. Apparently, OSHA had been unaware of the 1997 edition of CGA G-7.1 when they promulgated their final Respirator Standard, 29 CFR 1910.134 on 8 January, 1998; because they required compressed breathing air to meet at least the requirements for "Type I - Grade D" breathing air described in CGA 7.1-1989. However, the Type I and II terminology for breathing air was discontinued after the 1989 edition of CGA G-7.1. OSHA corrected this error to specify "Grade D" instead of "Type I - Grade D" in the 23 April 1998 Federal Register.
- c. To prevent SCBA valves from freezing, the 1997 and 2004 versions of CGA G-7.1 specified Grade L air for use with self-contained breathing apparatus (SCBA) worn in extreme cold because of the Grade L air low moisture requirements of 24 ppm and -65 ° F dew point. However, the only other requirement for Grade L air was the 19.5 to 23.5 % oxygen content. Although the low moisture requirement made sense, it did not make sense for Grade L air to not also require the same limiting characteristic requirements of Grade D air. This was corrected in the 2011 version of CGA G-7.1, in which

Grade L and Grade D have the same limiting characteristics, except for the more stringent moisture requirements of Grade L air for use in SCBA worn in extreme cold. Table 2 of CGA G-7.1 defines what the grades of air are used for. The industrial uses for CGA grades of air are listed below:

<b>CGA Grade</b>	<b>Industrial Uses</b>
A	Industrial compressed air
L	SCBA
D	OSHA breathing air
E	SCUBA
J	Specialty grade air, analytical applications
N	Medical/USP air

d. Table 1 of CGA G-7.1-2011, reference (5) lists maximum concentrations of the air constituents for each grade of compressed air. A blank box in the table indicates no maximum limiting characteristic. This does not mean that the substance is not present, but indicates that testing that component is not a requirement for compliance with the specification. Intuitively, one would think that like eggs, Grade A air would be the best air quality; however, Grade A air has the least stringent requirements. OSHA, the Navy, and ANSI Z88.2 base their breathing air purity requirements on CGA G-7.1 Grade D breathing air criteria, which basically have not changed since CGA G-7.1-1989 and are listed in the table below.

<b>TABLE 1 CGA G-7.1-2011 GRADE D COMPRESSED AIR PURITY REQUIREMENTS</b>	
<b>Characteristic</b>	<b>CGA G-7.1-2011 Requirements</b>
Oxygen content (v/v)	19.5%-23.5%
Oil (Condensed)	≤ 5 mg/m <sup>3</sup>
Carbon monoxide	≤ 10 ppm
Carbon dioxide	≤ 1,000 ppm
Water content	Dew point ≤ -50°F (67 ppm v/v). Note 6 states that for SCBA use in extreme cold a dew point not to exceed -65 °F (24 ppm v/v) or the dew point must be 10° F lower than the coldest temperature where the respirator is worn.
Odor	None (No pronounced odor)

### **III. GRADE D AIR LIMITING CHARACTERISTICS**

#### **A. Oxygen - 19.5% to 23.5%**

1. Paragraph (i)(2) of 29 CFR 1910.134 does not allow the use of compressed oxygen in atmosphere-supplying respirators that have previously used compressed air. This is to prevent a flammability hazard from high pressure oxygen coming in contact with any oil introduced inside the airline hoses from compressed air operations. Paragraph (i)(3) further requires that oxygen concentrations greater than

23.5% are used only in equipment designed for oxygen service or distribution (e.g., closed circuit respirators).

2. It may seem counterintuitive that oxygen content in compressed breathing air even need be sampled because air intakes located outdoors should contain 20.9% oxygen since that is its concentration in ambient, atmospheric air. Unfortunately, there is no guarantee that every employer will place air intakes in proper locations or properly maintain their air compressors. The *Navy Occupational Safety and Health Oversight Inspection Unit* found many compressed breathing air system problems involving improper use, testing, and maintenance.

3. Although air intakes are required to be properly located in fresh outdoor atmospheres such as above roof level and away from ventilation exhausts, they are sometimes improperly located outdoors on loading docks and exposed to vehicle exhaust. Depending on the circumstances, there could also be a chance of oxygen depletion by the presence of other substances where air intakes are improperly located. Oxygen can also be consumed inside of oil-lubricated compressors running hot in the presence of hydrocarbons.

4. Other factors to consider, which influence the oxygen concentration, include moisture in the air and altitude. Moisture is the most variable component of the atmosphere. Water vapor in the atmosphere can range from 0 to 4%. In dry air (0% water vapor), the oxygen concentration is approximately 20.9%. However, atmospheres with 4% water vapor contain only 20.06% oxygen.

$$\frac{20.9}{100} = \frac{X}{.96}$$

$$X = (20.9) (.96)/100 = 0.20064 \text{ or } 20.064\%$$

5. Also, at higher altitudes, the percentage of oxygen remains the same as at sea level. However, the partial pressure of oxygen decreases, which effectively lowers the oxygen concentration available for respiration as discussed in Appendix (A).

**B. Carbon monoxide (CO) - 10 ppm**

1. The 1973 standard listed the maximum limit for CO as 20 ppm. The limit for CO was changed in 1989 to 10 ppm. CO is the deadliest of the toxic gases commonly found in compressed air. Because CO is colorless and odorless, it is impossible for respirator wearers to detect. CO combines readily with hemoglobin in red blood cells and prevents the transfer of oxygen to the tissues, causing oxygen starvation or hypoxia.

2. Possible sources of CO include:

- a. Motor exhaust drawn into compressor air intake;
- b. Generated within compressors as combustion product of fuels, lubricants and overheated oils;

- c. Generated within compressors from oxidation of overheated sorbent filters. CO accumulated on a filter can be released when there is a drop in operating pressure.
- C. Oil - 5 mg/m<sup>3</sup> at NTP (normal temperature and pressure)
  - 1. Oil was formerly called condensed hydrocarbons in the 1973 edition of CGA G-7.1. Large particles of condensed hydrocarbons, or oil, can be removed by the body's clearance mechanisms (i.e., phagocytosis and [mucociliary escalator](#)). Smaller oil particles are retained, and may be hazardous, depending on the type and amount. Oil mist deposits in the alveoli can cause an intense inflammation, known as lipid pneumonia.
  - 2. Oil mist can also cause emphysema by dilating and rupturing the alveoli, thus decreasing the total surface area available for the transfer of oxygen and carbon dioxide. Possible oil sources include dust and pollen, motor exhaust pulled into the compressor air intake, and oil generated inside the compressor if lubricants escape through faulty piston rings.
- D. Carbon dioxide (CO<sub>2</sub>) - maximum 1000 ppm.
  - 1. Carbon dioxide stimulates the respiratory center. A buildup of CO<sub>2</sub> in breathing air increases the breathing rate, which can deplete SCBA air supply more rapidly and increase inhalation of other contaminants.
    - a. The CO<sub>2</sub> concentration is the more crucial than the lack of O<sub>2</sub> for controlling respiration because sensors in the carotid artery (which supplies blood to the brain) detect changes in the partial pressure of both O<sub>2</sub> and CO<sub>2</sub> (PO<sub>2</sub> and PCO<sub>2</sub>). However, PO<sub>2</sub> must be reduced by about half before the carotid artery sensors send a message to the respiratory control center in the medulla to breathe harder.
    - b. The cerebrospinal fluid, which surrounds the brain and spinal column is much more sensitive to changes in respiration than sensors in the carotid artery. It monitors PCO<sub>2</sub> levels in the blood indirectly by monitoring hydrogen ion concentrations. Most CO<sub>2</sub> in the blood is in the ionized form as carbonic acid and a hydrogen ion (CO<sub>3</sub><sup>-</sup> plus H<sup>+</sup>). The cerebrospinal fluid sensors actually monitor the hydrogen ion concentration. When hydrogen ion concentration changes, these sensors send messages to the respiratory control center almost instantaneously, which immediately restore proper respiration. Therefore, the CO<sub>2</sub> concentration is more crucial than the lack of O<sub>2</sub> for controlling respiration.
  - 2. High CO<sub>2</sub> levels can be indicative of compressor problems. Carbon monoxide is converted to CO<sub>2</sub> by hopcalite in the compressor CO filter. Therefore, high concentrations of CO<sub>2</sub> can result from the hopcalite catalyzing elevated concentrations of CO. Grade E air for self-contained underwater breathing apparatus (SCUBA) air was revised in the 1989 edition increasing the maximum allowable level for carbon dioxide from 500 ppm to 1,000 ppm.
- E. Odor - Grade D air should have no pronounced odor. Odor is a subjective measurement.

F. Water

1. Note 6 to Table 1 states that water content varies with intended use. Water vapor will vary depending on relative humidity and dew point. Basically, there should be no liquid water in the breathing air to prevent freezing in atmosphere-supplying respirators. According to Note 6 from Table 1 of CGA G-7.1, SCBA breathing air must not have a dew point temperature exceeding -65° F (which corresponds to a moisture content of 24 ppm v/v) or the dew point temperature of the breathing air at one atmosphere must be 10° F lower than the coldest temperature expected in the atmosphere where the respirator will be worn.

2. The lower the dew point, the lower the moisture content. If the ambient temperature falls below the dew point of compressed breathing air, any moisture present can condense and form liquid water. If the ambient temperature is freezing, then regulator and control valves can freeze. Adiabatic cooling further contributes to the problem of freezing. Adiabatic cooling occurs in atmosphere-supplying respirators as high pressure compressed air loses heat when its pressure is reduced. According to reference (6), when ambient temperature, high pressure air (2000 to 4000 psi and about 70°- 85°F) is reduced by the regulator to 80 to 100 psi for airline respirator use the air temperature drops 25° to 40°F or more.

3. Table 2 provides dew point temperatures, at one atmosphere of pressure, in five degree increments ranging from -110° F to 45° F. This table covers the temperature range most likely found in the workplace where adiabatic cooling produced by SCBA and airline respirators could cause freezing. Moisture measurements taken during compressed breathing air quality testing can be compared to these table values to convert between dew point and moisture content.

TABLE 2 DEW POINT TEMPERATURES AND CORRESPONDING MOISTURE CONTENT							
° F	° C	ppm (v/v)	mg/m <sup>3</sup>	° F	° C	ppm (v/v)	mg/m <sup>3</sup>
-110	-78.9	0.6	0.4	-30	-34.4	235	173
-105	-76.1	1	0.7	-25	-31.7	316	233
-100	-73.3	1.6	1.2	-20	-28.9	422	311
-95	-70.6	2	1.5	-15	-26.1	560	412
-90	-67.8	4	3	-10	-23.3	738	543
-85	-65	5	4	-5	-20.6	968	713
-80	-62.2	8	6	0	-17.8	1,262	929
-75	-59.4	12	9	5	-15	1,636	1,204
-70	-56.7	17	13	10	-12.2	2,109	1,553
-65	-53.9	24	18	15	-9.4	2,704	1,991
-60	-51.1	34	25	20	-6.7	3,450	2,540
-55	-48.3	48	35	25	-3.9	4,381	3,225
-50	-45.6	67	49	30	-1.1	5,537	4,076
-45	-42.8	92	68	35	1.7	6,850	5,043
-40	-40	127	94	40	4.4	8,353	6,150
-35	37.2	173	127	45	7.2	10,144	7,468

a. Please note that Clause 10.5.4.4 of ANSI Z88.2-1992 recommends that the dew point of breathing air used with airline respirators should be lower than the lowest ambient temperature to which any regulator or control valve on the

respirator or air-supplied system will be exposed. Clause 10.5.3 recommends that the dew point of air used to recharge SCBA be -65° F or lower. ANSI Z88.2 further requires that when ambient temperatures are below -25° F, to recharge SCBA cylinders with the driest air obtainable, that is air with a dew point of -100° F or lower.

b. OSHA (29 CFR 1910.134(i)(5)(ii)) requires that the dew point of compressed breathing air at one atmosphere pressure must be 10° F below the ambient temperature. Paragraph 29 CFR 1910.134(i)(4)(iii)) requires that the moisture content in cylinders of breathing air purchased from suppliers does not exceed a dew point of -50° F (-45.6° C) at one atmosphere pressure.

c. Table 2 lists **atmospheric** dew point temperatures and their corresponding moisture contents. However, the “*pressure dew point temperature*” of compressed breathing air becomes a critical factor in evaluating air quality of breathing air use in extremely cold temperatures, such as occur in some geographic locations, such as in Canada and Alaska. The increased pressure of breathing air for atmosphere supplying respirator results in the “*pressure dew point temperature*” of the compressed air being considerably lower than the dew point of ambient air (at one atmosphere of pressure) with the same temperature.

d. Table 3, adapted from CSA Z180.1 (reference (7)) and draft ANSI Z88.2, takes into account pressure dew point temperatures at typical operating pressures of airline respirators and is used for determining the allowable moisture content to protect against valve freezing. To use Table 3, locate the operating pressure for the airline respirator and find the lowest temperature in which the respirator will be used, then read the maximum water content from the left column.

Table 3 Compressed Air Moisture Content Airline Respirators									
Maximum Water content measured at atmospheric dew point and temperature	Lowest use temperature								
	50 psig (344.8 kPa)		75 psig (517.1 kPa)		100 psig (689.5 kPa)		125 psig (861.9kPa)		
ppm (ml/m <sup>3</sup> )	°C	°F	°C	°F	°C	°F	°C	°F	
844	-1	31							
693	-3	27	0	34					
567	-6	22	-2	30					
463	-8	19	-4	25	-1	31			
377	-10	15	-7	21	-4	26	-2	30	
305	-12	11	-9	17	-6	22	-4	26	
247	-15	7	-11	13	-9	18	-7	22	
199	-17	3	-13	9	-11	13	-9	17	
159	-19	-1	-16	5	-13	9	-11	13	
127	-21	-5	-18	0	-16	5	-14	9	
101	-23	-9	-20	-4	-18	1	-16	4	
80	-26	-13	-23	-8	-20	-4	-18	0	
63	-28	-17	-25	-12	-22	-8	-21	-4	
50	-30	-21	-27	-16	-25	-12	-23	-9	
39	-33	-26	-30	-20	-27	-16	-26	-13	
30	-35	-29	-32	-24	-30	-20	-28	-17	

e. Table 4, adapted from CSA Z180.1 and draft ANSI Z88.2, takes into account pressure dew point temperatures at typical operating pressures of SCBA and is used for determining the allowable moisture content to protect against valve freezing. To use Table 4, locate the operating pressure of the SCBA and find the lowest temperature in which the respirator will be used, then read the maximum water content from the left column.

<b>Table 4</b> <b>Moisture Content</b> <b>High Pressure Compressed Air Cylinders</b>						
<b>Maximum Water content measured at atmospheric dew point and temperature</b>  <b>ppm (ml/m<sup>3</sup>)</b>	<b>Lowest use temperature</b>					
	<b>2216 psig (15.3 MPa)</b>		<b>3000 psig (20.7 MPa)</b>		<b>4500 psig (31.0 MPa)</b>	
	°C	°F	°C	°F	°C	°F
27	-7	20	-6	23	-5	23
24	-8	19	-7	20	-7	20
21	-10	16	-9	18	-9	17
18	-11	13	-10	15	-10	15
15	-13	11	-12	12	-12	12
14	-14	8	-13	9	-14	9
12	-16	5	-15	6	-15	6
11	-18	2	-16	4	-17	3
9	-19	0	-18	1	-18	0
8	-20	-3	-19	-2	-20	-3
7	-22	-6	-21	-4	-22	-6
6	-23	-8	-22	-7	-23	-9
5	-24	-11	-24	-10	-25	-12
5	-26	-14	-25	-13	-26	-15
4	-27	-16	-27	-15	-28	-17
4	-29	-19	-29	-18	-30	-20
3	-30	-22	-30	-21	-31	-23
3	-32	-24	-32	-24	-33	-26
2	-33	-27	-33	-26	-34	-29

G. Other Contaminants - There are no limits for other contaminants (total hydrocarbon, nitrogen dioxide, nitric acid, sulfur dioxide, etc.) listed in Table 1 of CGA G-7.1-2004 for Grade D air. However, these should be tested if there is any reason to suspect a problem.

#### IV. **TESTING BREATHING AIR**

A. The Navy requires analyzing breathing air quality quarterly to ensure it meets Grade D criteria. A pressure reducer must be placed in line before the air is sampled. Test procedures are given in sections 4 and 5 of CGA G-7.1. The following methods are recommended for testing breathing air quality:

1. Oxygen - colorimetric detector tubes or oxygen meter (preferred method)
2. Water - colorimetric detector tubes
  - a. Permanent dew point meters can be installed on sources of compressed breathing air to continuously monitor moisture content.
  - b. These measurements can be used for quarterly air quality testing. Follow all manufacturer's instructions.



3. Condensed oil - collect on glass-fiber filter and analyze gravimetrically or measure using a detector tube. Be careful, some oil detector tubes contain sulfuric acid.
4. Odor - sniff a moderate flow of air. Do not place your face directly in front of the valve. Cup your hand and waft a sample up to your nose.
5. Carbon monoxide and carbon dioxide - colorimetric detector tubes
  - a. Permanent CO meters and alarms can be installed on sources of compressed breathing air to continuously monitor CO concentration.
  - b. These measurements may be used for quarterly air quality testing if the apparatus is maintained and calibrated per manufacturer's instructions.
    - i. Compressors equipped color-change CO and moisture indicators do not meet the OSHA requirements for CO alarms. Page 47 of [\*OSHA's Questions and Answers on the Respiratory Protection Standard\*](#) states the following about CO indicators:

*The color change in color-change indicators which detect the presence of CO in breathing air is a warning of the presence of moisture in the breathing air that is trapped in the filter. Moisture can render the filter ineffective. Thus, the color-change indicator cannot be used to detect the presence of carbon monoxide.*

B. Commercially available air test kits. Air quality testing can also be contracted. See Appendix (B) for a list of breathing air test kits and companies that perform breathing air sample analysis. The reader should be aware that other suitable services may also be or become available.

C. Locations to Test Breathing Air Sources

1. Scenario 1 - If the air is not filtered nor tested at the large compressor and individual breathing air stations are equipped with filtering systems, then sample each of these breathing air stations quarterly.
2. Scenario 2 - If the air is filtered and tested quarterly at the compressor and sent to breathing air stations without filters then sample one fourth of breathing air stations quarterly so that in one year all of the breathing air stations serviced by the compressor are tested. Blow out the lines prior to use.
3. Scenario 3 - Air from a large compressor is stored in a large air tank (accumulator). The air is continuously monitored for CO and the dew point. The air is transferred by a piping network to "risers" at various locations throughout the command.
  - a. Quarterly air quality samples should be taken at specified locations in the distribution system that are representative of the whole system.
  - b. When specifying sample locations, consideration must be given to the parts of the air distribution system with dead legs and low volume usage. Therefore, collect samples at risers that have a potential for use.

- c. When a breathing air station is required to be connected to the raiser, first blow out the pipes in the air distribution system at the riser to ensure that:
  - i. all valves leading to the riser are open;
  - ii. there is sufficient air volume;
  - iii. sediment in the air distribution lines is removed.
- d. After the system blow down, connect breathing air distribution lines and portable filtration boxes for supplied air respirators.

D. An example of a standard operating procedure for testing compressed breathing air quality is Appendix (C). This procedure is adapted from the fleet maintenance requirement card addressing this issue.

## V. COMPRESSOR REQUIREMENTS

A. Oil-Lubricated Compressors - Reciprocating compressors (piston compressors) are the workhorses of the workplace. Most are oil-lubricated to extend service life. When oil is in the crankcase, it will predictably be discharged into the compression chamber. Compressors are either oil-lubricated or non-oil-lubricated. Most non-oil-lubricated compressors use Teflon<sup>®</sup> parts.

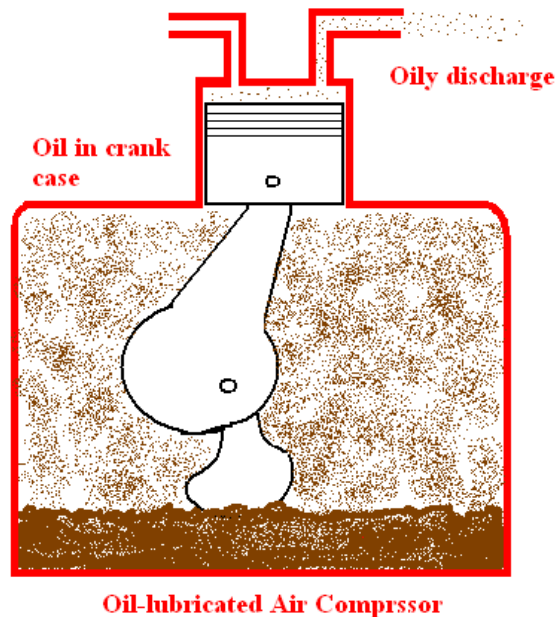

B. Oil-Less Compressors - Oil-less is another name for non-oil-lubricated compressors because they have no oil in the crankcase. Oil-less reciprocating compressors use sealed bearings and the piston rings are made from self-lubricating Teflon<sup>®</sup>. The Teflon<sup>®</sup> rings seal the cylinder bore and reduce friction. To further reduce heat, “force-compensated piston ring” design is used in which the Teflon<sup>®</sup> rings ride on a cushion of air, sealing during compression stroke and releasing during intake stroke, which reduces friction and pressure forces on the rings. Teflon<sup>®</sup> thermally decomposes at 752° F. However, compressor manufacturers set their high temperature alarms to shut off the compressors well before this temperature is ever reached. Particles of Teflon<sup>®</sup> (median size 1.1

micron) will be produced especially during the early use of new compressors, but these are filtered out by the mechanical filtration system required on the compressors. Residual heat from compression and friction is removed by forced-air cooling - usually by a blower wheel mounted on the end of the motor shaft directing air over the pistons, cylinders, and bearings to cool them. Oil-less, piston air compressors are available with 1/12 to 15 horsepower and with pressure rating up to 220 psi.

1. Other oil-less compressors include carbon vane compressors and diaphragm compressors, which are limited to maximum operating pressures of 15 psi and 100 psi, respectively. Carbon vanes are self-lubricating on cast iron in the presence of humidity in the atmosphere.
2. Diaphragm compressors are oil-less because the diaphragm completely isolates the crankcase from the compression chamber.

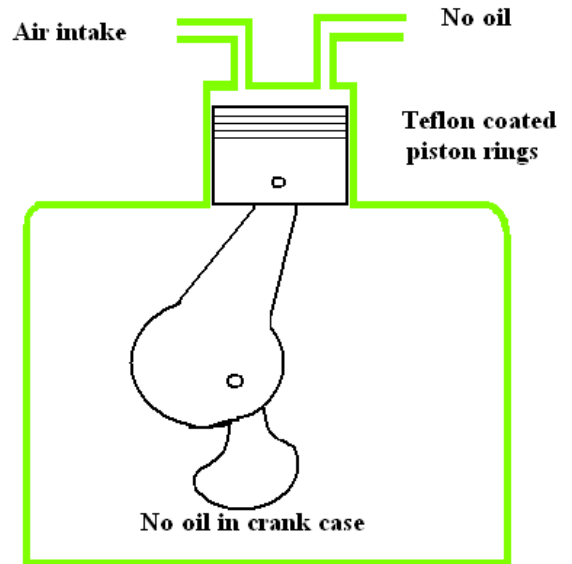

**Oil-less Air Compressor**

C. Oil-Free Compressors - The term, oil-free compressor is misleading. These compressors actually have oil in the crankcase but are sealed such that oil cannot contaminate the compression chamber until the seals eventually wear or break.

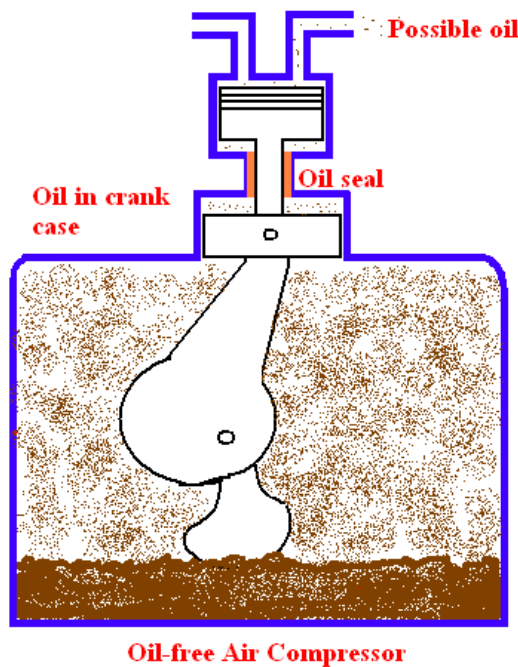

**Oil-free Air Compressor**

## VI. STANDARD SPECIFIC COMPRESSOR REQUIREMENTS

A. OSHA - According to 29 CFR 1910.134(i)(5), compressors supplying breathing air to respirators must be constructed and situated so as to prevent entry of contaminated air into the air-supply system. For example, air intakes must not be located on a loading dock because carbon monoxide levels will skyrocket! Suitable in-line air-purifying sorbent beds and filters are required to further ensure breathing air quality. Sorbent beds and filters must be maintained and replaced or refurbished periodically following the manufacturer's instructions. Examples of sorbents include molecular sieves, charcoal, desiccants, and hopcalite. OSHA also requires that sorbents be periodically maintained following the manufacturer's instructions and further states: "*Have a tag containing the most recent [sorbent] change date and the signature of the person authorized by the employer to perform the change. The tag shall be maintained at the compressor.*"

1. Unlike the original OSHA Respirator Standard, the 1998 standard does not require a receiver of sufficient capacity to enable the respirator wearer to escape from a contaminated atmosphere in event of compressor failure. This is because airline respirators are no longer allowed for entry into IDLH atmospheres and therefore do not require a receiver tank that holds enough air to escape on. However, if an air receiver is used to supply breathing air it must be maintained according to 29 CFR 1910.169, *Compressed Gas and Compressed Air Equipment, Air Receivers*.

2. Paragraph 29 CFR 1910.134(i)(7) requires that oil-lubricated compressors must be equipped with high-temperature or carbon monoxide alarms, or both, to monitor carbon monoxide levels. If only high-temperature alarms are used, the air supply shall be monitored at intervals sufficient to prevent carbon monoxide in the breathing air from exceeding 10 ppm.

a. High temperature alarms are for the protection of the compressor, while carbon monoxide monitor and alarm systems are for the protection of the worker. High temperature alarms will not detect carbon monoxide entering the compressor at the air inlet or produced inside the compressor. The locations of high temperature alarms on compressors vary. When the alarm sounds depends on the location of the alarm sensor. The respirator wearer could already be breathing carbon monoxide by the time the high temperate alarm signals.

b. To help emphasize the importance of controlling CO in compressed breathing air to safe levels, see the [NIOSH report](#) of a worker's death caused by breathing excess CO from their airline respirator.

3. Paragraph 29 CFR 1910.134(i)(6) states that the breathing air produced by non-oil-lubricated compressors must not contain carbon monoxide levels exceeding 10 ppm. This requirement can be met by several different methods (or combination of methods) including the use of the following:

- a. Continuous carbon monoxide monitors and alarm systems;
- b. Carbon monoxide filters;
- c. Proper air intake location in an area free of contaminants;

d. The use of high-temperature alarms and automatic shutoff devices, as appropriate.

4. Per [OSHA Memo from John B. Miles, Jr. Questions and Answers on the Respiratory Protection Standard. of 3 Aug 1998](#) electrochemical sensors used for periodic and continuous monitoring of breathing air must be calibrated periodically, usually monthly, to perform accurately. The measurement error for most electrochemical sensors is 5%. Also, as mentioned under Section IV.A.5, color change indicators, cannot be used to detect the presence of carbon monoxide in breathing air. The color change in the indicator is a warning of the presence of moisture in the breathing air that is trapped in the filter, which can render the CO hopcalite filter ineffective.

B. OPNAVINST 5100.23 Series - In addition to quarterly air quality monitoring to ensure Grade D breathing air, paragraph 1506 requires compressor systems to be equipped with either-high temperature or continuous carbon monoxide monitor and alarm systems or both to monitor carbon monoxide levels. If only high-temperature alarms are used, the air supply shall be monitored at intervals sufficient to prevent carbon monoxide in the breathing air from exceeding 10 ppm. Furthermore, **all new and/or upgraded** air compressor systems **must be equipped** with continuous carbon monoxide monitor and alarm systems. Another requirement of this paragraph is to **calibrate** monitor and alarm systems on compressors used for supplying breathing air according to the manufacturer's instructions.

C. OPNAVINST 5100.19 Series - Per paragraph B0611, the compressor requirements include quarterly testing to ensure Grade D quality before use and locating air intakes in clean air. Also, paragraph B0611.e. states:

*“Ships shall equip compressor systems with either high-temperature or carbon monoxide monitor and alarm systems or both, to control carbon monoxide levels. High-temperature cut-off switches on fixed compressors, which shut down the compressor at a temperature below which the lubricating oil breaks down (i.e., thermal degradation point), meet the requirement for high-temperature alarms, provided that quarterly monitoring meets the requirements for Grade-D breathing air. Ships shall equip all new and/or upgraded FIXED breathing air compressor systems with high-temperature cut-off switches. New and/or upgraded PORTABLE breathing air compressor systems will be equipped or operated with carbon monoxide monitor and alarm systems during SCBA air cylinder charging operations. Calibrate monitor and alarm systems on compressors used for supplying breathing air according to the manufacturer’s instructions.”*

## **VII. HIGH TEMPERATURE ALARMS**

A. Manufacturers of air compressors state in their equipment manuals what the maximum allowable temperature is for their compressors. According to *ANSI/ASME B19.3-1991, Safety Standard for Compressors for Process Industries*, which has been withdrawn from publication, high temperature alarms on compressors are to be set to trigger the alarm at least 25° F lower than the maximum allowable temperature. They also specify that a shutdown device to stop the compressor driver be installed and set at the maximum allowable temperature for the compressor.

B. ANSI B19.3-1973 used to require high temperature alarms on compressors to be set at 350° F. However, with the new synthetic lubricants and larger spectrum of compressors, the 350° F trigger was no longer appropriate for every situation.

### **VIII. BREATHING AIR COUPLINGS**

A. Paragraph (i)(8) of 29 CFR 1910.134 requires that airline couplings be incompatible with outlets for other gas systems. This prevents inadvertent servicing of airline respirators with non-respirable gases or oxygen.

B. This paragraph also states that no asphyxiating substance shall be introduced into the breathing air lines. For example, nitrogen cannot be used to blow the lines out.

### **IX. REFERENCES**

---

1. Occupational Safety and Health Administration (OSHA): 29 CFR Parts 1910 and 1926 Respiratory Protection: Final Rule. Federal Register 63(5):1278–1279. Washington, D.C.: U.S. Government Printing Office, Office of the Federal Register, January 8, 1998.

[http://www.osha.gov/pls/oshaweb/owadisp.show\\_document?p\\_table=STANDARDS&p\\_id=12716](http://www.osha.gov/pls/oshaweb/owadisp.show_document?p_table=STANDARDS&p_id=12716)

2. OPNAVINST 5100.23 Series.

<http://doni.daps.dla.mil/Directives/05000%20General%20Management%20Security%20and%20Safety%20Services/05-100%20Safety%20and%20Occupational%20Health%20Services/5100.23G.pdf>

3. PHONCON OSHA Mr. J. Steelnack/NAVMCPUBHLTHCEN Mr. D. Spelce of 29 Jan 98

4. OPNAVINST 5100.19 Series.

<http://doni.daps.dla.mil/allinstructions.aspx?RootFolder=/Directives/05000%20General%20Management%20Security%20and%20Safety%20Services/05-100%20Safety%20and%20Occupational%20Health%20Services&View={1FF912B1-1BC6-444A-8943-B769C77880F2}>

5. Compressed Gas Association (CGA). CGA G-7.1-2004, Commodity Specification For Air. CGA, Arlington, VA. 2011.

6 Noonan GP, Linn HI, and Reed LD. (1986) A Guide to Respiratory Protection for the Asbestos Abatement Industry, EPA publication no. DW75932235-01-1. Washington, D.C.: U.S. Environmental Protection Agency, Office of Pesticide and Toxic Substances.

7 CAN/CSA-Z180.1-2000 (R2010) - Compressed Breathing Air and Systems

**APPENDIX A  
ALTITUDE EFFECT ON OXYGEN CONCENTRATION**

**I. ALTITUDE EFFECT ON OXYGEN CONCENTRATION**

A. Altitude is a factor which effects the concentration of oxygen both in ambient air and in compressed breathing air. The Occupational Safety and Health Administration (OSHA) states, in paragraph (d)(2)(iii) of reference (1), that all oxygen-deficient atmospheres (less than 19.5% O<sub>2</sub> by volume) shall be considered immediately dangerous to life or health (IDLH) and that personnel entering these atmospheres must wear either self-contained breathing apparatus (SCBA) or combination airline/SCBA.

B. There is an exception when the employer can demonstrate that, under all foreseeable conditions, the oxygen concentration can be maintained within the ranges at the altitudes specified in Table II of the OSHA Respirator Standard (reproduced below), then any atmosphere supplying respirator, including airline respirators may be used.

<b>Table II 29 CFR 1910.134</b>	
Altitude (ft.)	Oxygen deficient Atmospheres (% O <sub>2</sub> ) for which the employer may rely on any atmosphere-supplying respirator
Less than 3,001	16.0-19.5
3,001-4,000	16.4-19.5
4,001-5,000	17.1-19.5
5,001-6,000	17.8-19.5
6,001-7,000	18.5-19.5
7,001-8,000	19.3-19.5

C. At high altitudes, OSHA (reference (1)) and ANSI Z88.2-1992 (reference (2)), require oxygen-enriched breathing air for atmosphere-supplying respirators.

D. However, OSHA allows acclimated workers to perform their work without atmosphere-supplying or oxygen-supplying respirators, at altitudes up to 14,000 feet altitude, as long as the ambient oxygen content remains above 19.5%.

**II. REFERENCES**

---

1. Occupational Safety and Health Administration (OSHA): 29 CFR Parts 1910 and 1926 Respiratory Protection: Final Rule. Federal Register 63(5):1278–1279. Washington, D.C.: U.S. Government Printing Office, Office of the Federal Register, January 8, 1998.

[http://www.osha.gov/pls/oshaweb/owadisp.show\\_document?p\\_table=STANDARDS&p\\_id=12716](http://www.osha.gov/pls/oshaweb/owadisp.show_document?p_table=STANDARDS&p_id=12716)

2. American National Standards Institute (ANSI): American National Standard for Respiratory Protection (ANSI Z88.2). New York: ANSI, 1992.

**APPENDIX B  
BREATHING AIR QUALITY TEST KITS**

**I. PMS USERS**

A. If you use the Navy Planned Maintenance System (PMS), refer to MRC Number C5DU (Q-1R), E2XR (M-1: MCM, PC), G3PG (LCS-1), and G6BE (LCS-2) or equivalent maintenance requirements for Analyzing Charging System Air Quality. These procedures outline the general testing procedure and equipment authorized by NAVSEA.

Disclaimer: This list is provided to assist you with contacting manufacturers of breathing air test kits. It may not contain the names of all manufacturers or suppliers of such kits. Listing does not constitute endorsement by the Department of Defense, the Navy or the Navy and Marine Corps Public Health Center.

Manufacturer / Company	Breathing Air Test Kit
Dräger Safety, Inc. Distributed by AFC International, Inc. 715 SW Almond St, Ste A DeMotte, IN 46310 800-952-3293 or 219-987-6825 FAX 219-987-682 <a href="http://www.afcintl.com/resp5.htm">http://www.afcintl.com/resp5.htm</a>	Aerotest System  Low Pressure (150 psi) Part # 4054001  High Pressure (4500 psi) Part # 4055986
Air Quality Laboratories, Inc. 961 Doral Drive Bartlett, IL Phone: 630-830-4018 <a href="http://airqualitylab.freesevers.com/">http://airqualitylab.freesevers.com/</a>	Compressed Air Sampling Kit (Kit is purchased from company - return for analysis)
Air Systems International, Inc. 829 Juniper Crescent Chesapeake, Virginia 23320 Toll Free: 800-866-8100 <a href="http://www.airsystems.cc/product_pages/filtration/breathing_air_quality_test_kits.htm">http://www.airsystems.cc/product_pages/filtration/breathing_air_quality_test_kits.htm</a>	Compressed Air Sampling Kit (Kit is purchased or rented by company – return for analysis)
Analytical Chemists, Inc. 7551 Convoy Ct, San Diego, CA 92111 Voice & Fax (858) 560-4916 <a href="http://www.airanalysis.com/">http://www.airanalysis.com/</a>	Compressed Air Sampling Kit (Kit is loaned by company – return for analysis). Also provides <a href="#">Instant Air Analysis kits</a> for onsite testing.
Sensidyne 16333 Bay Vista Drive Clearwater, Florida 33760 800-451-9444 727-530-3602 FAX 727-539-0550 <a href="http://www.sensidyne.com/">http://www.sensidyne.com/</a>	AirTech Breathing Air Analysis Kit Part # <a href="#">7015406</a>
Texas Research Institute 9063 Bee Caves Rd. Austin, TX 78733-6201 800-888-TEST (512) 263-2101 FAX 512-263-2558 <a href="http://airtesting.com/compressed-air-testing/graded-osha/">http://airtesting.com/compressed-air-testing/graded-osha/</a>	Compressed Air Sampling Kit (Kit is loaned by company - return for analysis)



<b>Manufacturer / Company</b>	<b>Breathing Air Test Kit</b>
X-Zam Laboratories 4740 NW 157 Street, Miami Lakes, Florida 33014 305-430-0550 or 800-338-5493 <a href="http://www.lawrence-factor.com/direc_airanalysis.html">http://www.lawrence-factor.com/direc_airanalysis.html</a>	Compressed Air Sampling Kit (Kit is loaned by company – return for analysis)

**APPENDIX C**  
**QUARTERLY AIR QUALITY TESTING**  
**BREATHING-AIR COMPRESSORS**

**I. DISCLAIMER**

This is an example of a standard operating procedure for testing compressed breathing air quality. It is adapted from the fleet maintenance requirement cards, so the mention of manufacturers and specific models is for illustrative purposes only. It does not constitute an endorsement by the Navy and Marine Corps Public Health Center or the Department of the Navy. Always follow specific manufacturers' directions for the equipment you are using.

**II. INTRODUCTION**

A. Paragraphs B06011 and 1506 of references (1) and (2) require testing air quality of compressors used to supply breathing air to atmosphere supplying respirators on a quarterly basis. This is to ensure that the breathing air delivered to atmosphere supplying respirators meets or exceeds Grade D quality air as defined in reference (3). Testing compressor air quality should also be performed whenever contamination of the compressed air source is suspected. If the air sample fails to meet the acceptance criteria, then the air source must not be used for breathing air until re-sampling and analysis conforms with reference (3) Grade D air. The following procedure is based on the method used by the fleet to test compressed air quality and describes using the following air quality testing apparatus:

1. Biosystems [PHD Ultra Four-Gas Analyzer](#) (Mfr part number 54-02-30102N-7) was the original equipment used to test oxygen concentration.
  - a. Note: The PHD Ultra is no longer available for purchase and current SPMIG applies to [Biosystems PHD6 Six-Gas Analyzer](#) (Mfr part number 54-53-A0102800N7).
  - b. Both the PHD and the PHD6 may be used to measure oxygen.
2. Dräger Breathing Air Test Kit, Aerotest Simultan (National Dräger part number 6525960) is used to determine the concentration of water vapor, oil, carbon monoxide (CO), and Carbon Dioxide (CO<sub>2</sub>) contained in high-pressure compressed breathing air used for charging self contained breathing apparatus. The compressed air source pressure is reduced by an air test kit reducer. The following detector tubes are used to evaluate the individual components of air during air quality testing:

Air Component	Dräger Part No.
Water Vapor (H <sub>2</sub> O) 20/a-P	8103061
Oil PN*	8103111
Carbon Monoxide (CO) 5/a-P	6728511
Carbon Dioxide (CO <sub>2</sub> ) 100/a-P	6728521

\* Internal reagent ampoule in oil detector tube contains concentrated sulfuric acid. Exercise caution when handling oil detector tubes. Do not permit contents of detector tubes to come into contact with exposed skin. Wear protective gloves, such as 6 mil nitrile gloves and safety goggles when fracturing and handling the oil test tube.

### III. PRELIMINARY

- A. Prepare the air compressor for operation according to normal operating procedures.
- B. While wearing safety goggles visually inspect the breathing air source connection for contamination. Clean breathing air source connection by allowing air to momentarily blow through connection.

**WARNING:** Ensure all residual air pressure is relieved from equipment before loosening components or fittings.

- C. Attach the air test kit adapter, reducer, and measuring device to Fill Hose Assembly as shown in Figure 1. Use a wrench to connect air test kit reducer to air test kit measuring device. All other connections should be hand tightened only.

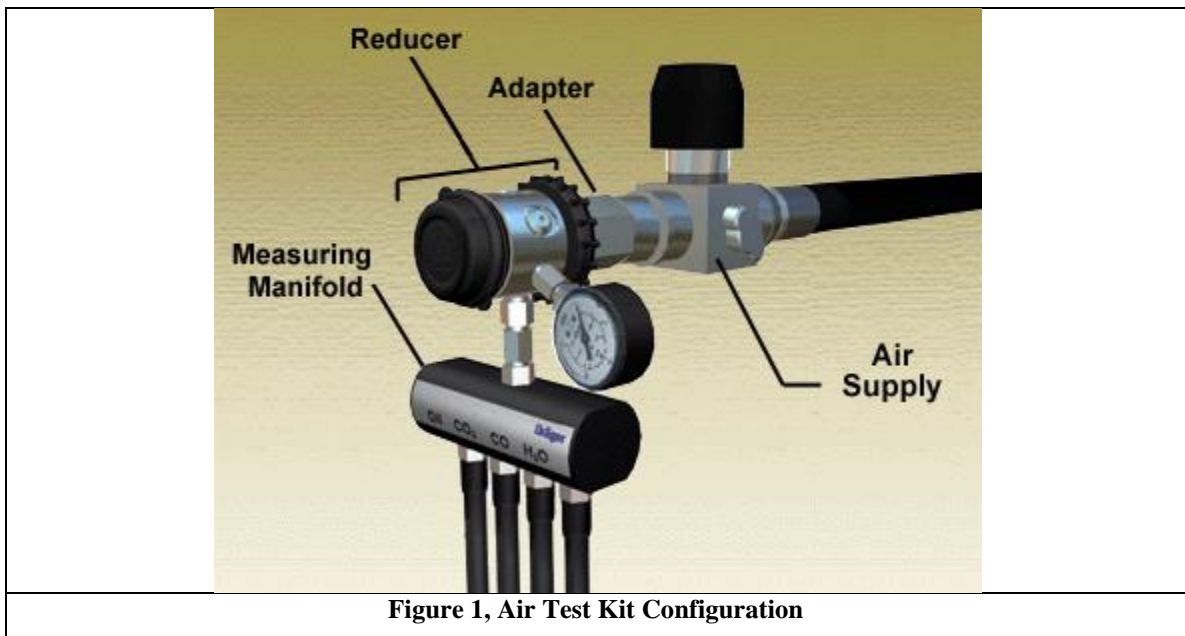

- D. Slowly open the breathing air source and allow air to flush through the measuring device for at least 3 minutes.
- E. Shut the breathing air source.

#### IV. ANALYZE CHARGING AIR QUALITY

**WARNING:** Corrosive mist escapes from outlet end of some Dräger tubes during measurements. Avoid direct skin contact with outlet areas of tubes and tube holders during and after measurements. After taking measurements, rinse outlet end of each tube holder and Dräger Accuro pump thoroughly in a pail with fresh water.

A. Carefully score and break off tips of Dräger tubes for oil, carbon monoxide, and carbon dioxide using tube opener. Break off both ends of each tube.

**WARNING:** To avoid possible eye injury from broken glass, wear safety goggles when scoring and breaking tube ends. Handle tubes carefully - tube ends are sharp.

B. Insert tubes into tube holders of measuring device at the space marked for each appropriate tube. Flow arrow on tubes must point away from the measuring device. Refer to Figure 2.

1. Chemicals in the water vapor tube are extremely sensitive to moisture and humidity. Tube and tube holder must be kept free from moisture during handling and use. Follow instructions carefully and do not open water vapor tube until just prior to measurement.

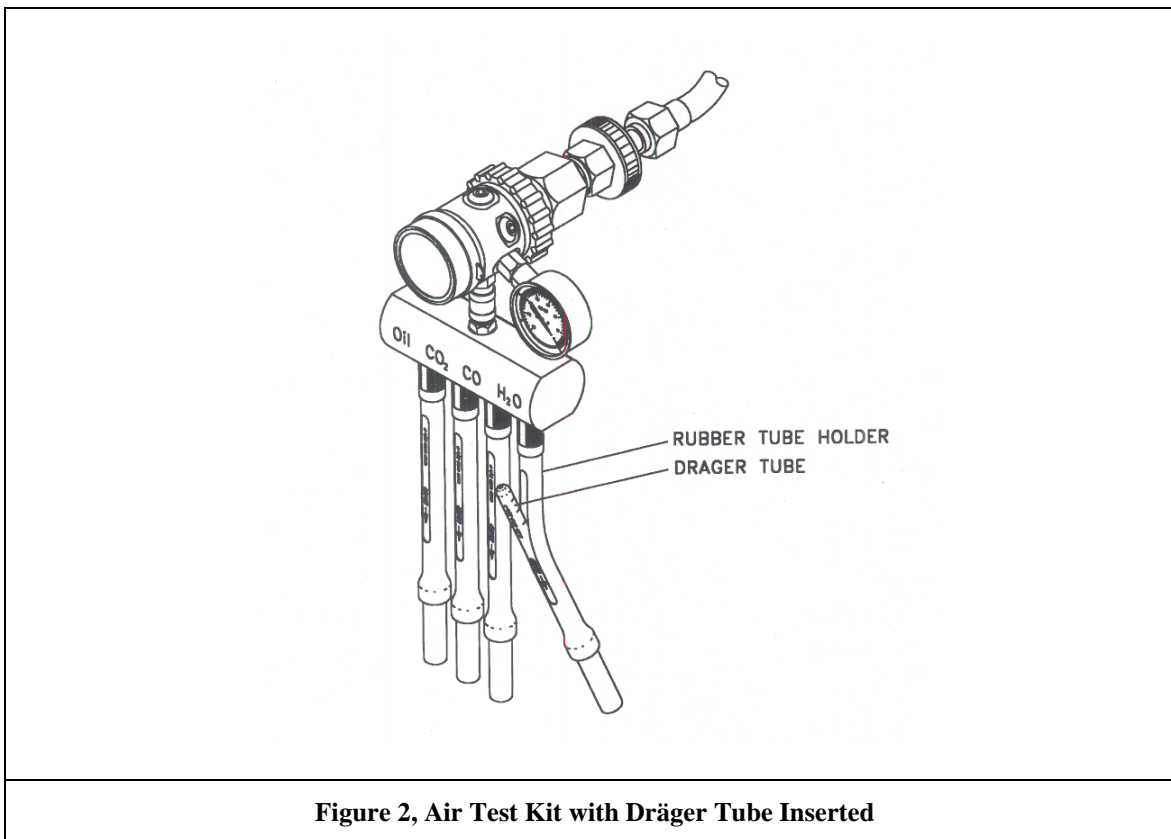

- a. Score and break off outlet end of water vapor tube using tube opener.
- b. Score inlet end of water vapor tube using tube opener; do not break off at this time.

- c. Insert outlet end of water vapor tube into outlet end (lower end) of its tube holder. Position tube so that 10 minutes scale is clearly visible when fully installed in tube holder.
  - d. Break off inlet end tip of water vapor tube using tube opener then immediately insert tube end into tube holder.
- C. Slowly open breathing air source and start electronic timer.
- 1. Oil, carbon monoxide, and carbon dioxide tubes are calibrated for an exposure time of five minutes.
  - 2. Remove oil, carbon monoxide, and carbon dioxide tubes from tube holder after five minutes of exposure. Continue water vapor testing for 10 minutes.
    - a. Evaluate measurement for carbon monoxide and carbon dioxide according to the scale provided on respective Dräger tubes. Refer to the table below for acceptance test criteria.

Constituent	Allowable Measured Value per this Test Method
Carbon Monoxide (CO)	Between zero and 10 ppm
Carbon Dioxide (CO <sub>2</sub> )	Between zero and 1000 ppm

- b. Bend the oil test tube sharply at the indicated position (between double dots), so that the outer glass tube and internal reagent ampoule break. Allow ampoule fluid to flow into the indicating layer of the tube. Use Draeger Accuro pump to apply light suction to outlet of tube or hold tube such that gravity brings ampoule fluid to cover approximately 1/2" (roughly one detector tube diameter) of the indicating layer.

**WARNING:** The internal reagent ampoule in oil test tube contains concentrated sulfuric acid. Exercise caution when handling the oil test tube. Do not permit contents of tube to come into contact with exposed skin. Wear protective gloves, such as 6 mil nitrile gloves and safety goggles when fracturing and handling the oil test tube.

- i. Wait 1 minute before interpreting results. If no color change occurs in indicating layer, concentration of oil in air sample is less than 5 mg/m<sup>3</sup> and is acceptable. See Figure 3.

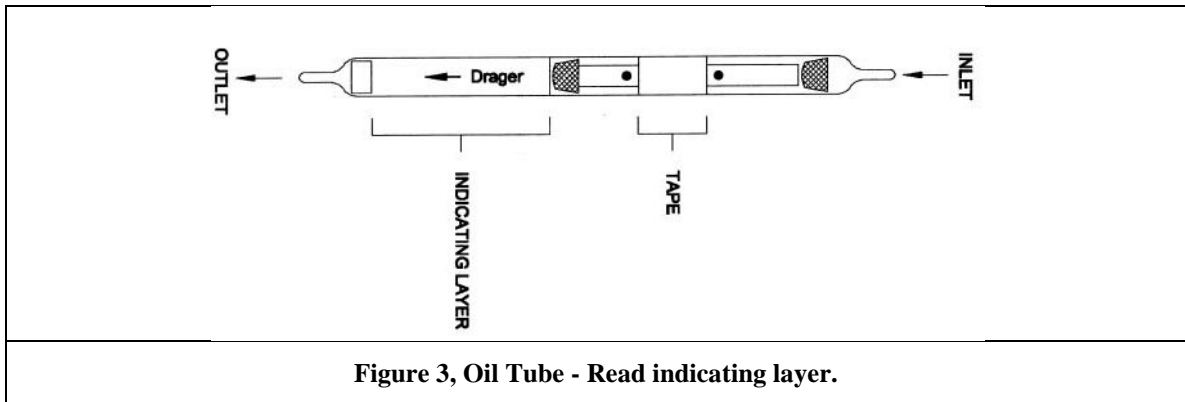

D. Remove the water tube from tube holder after 10 minutes on the timer and read measurement. A color change to reddish-brown is an indication of moisture.

1. A reddish-brown color is an indication of water and is used to determine the level of moisture within the air sample. There are several color changes during this chemical reaction before turning reddish-brown. Read only the reddish-brown level. See Figure 4.
2. Read level of moisture on 10 minute scale of the tube. Acceptance criteria for water vapor is less than or equal to 20 mg/m<sup>3</sup>.

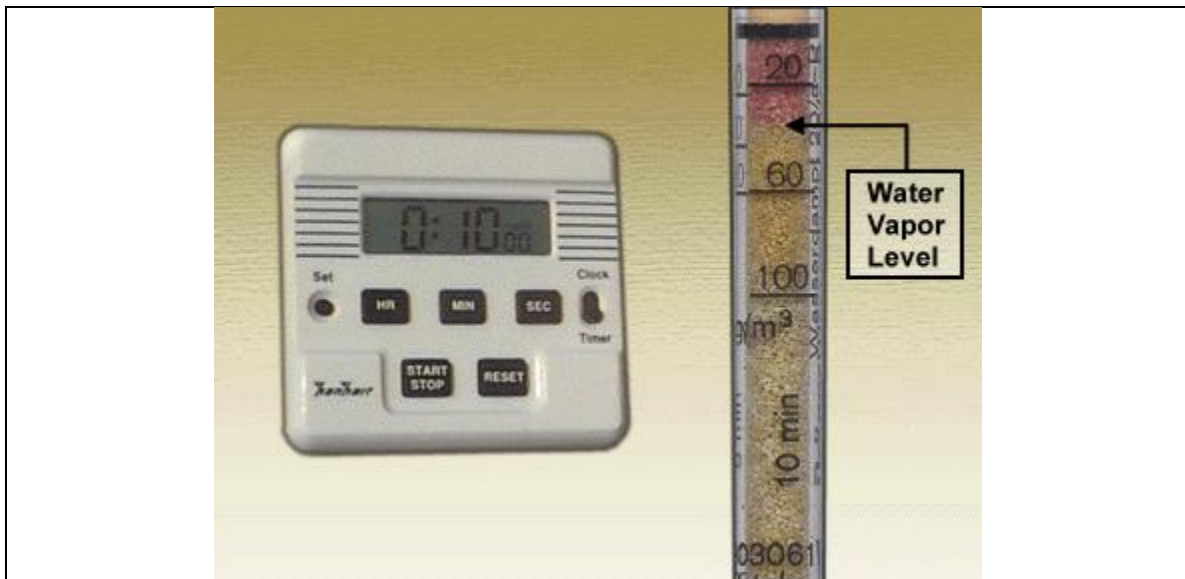
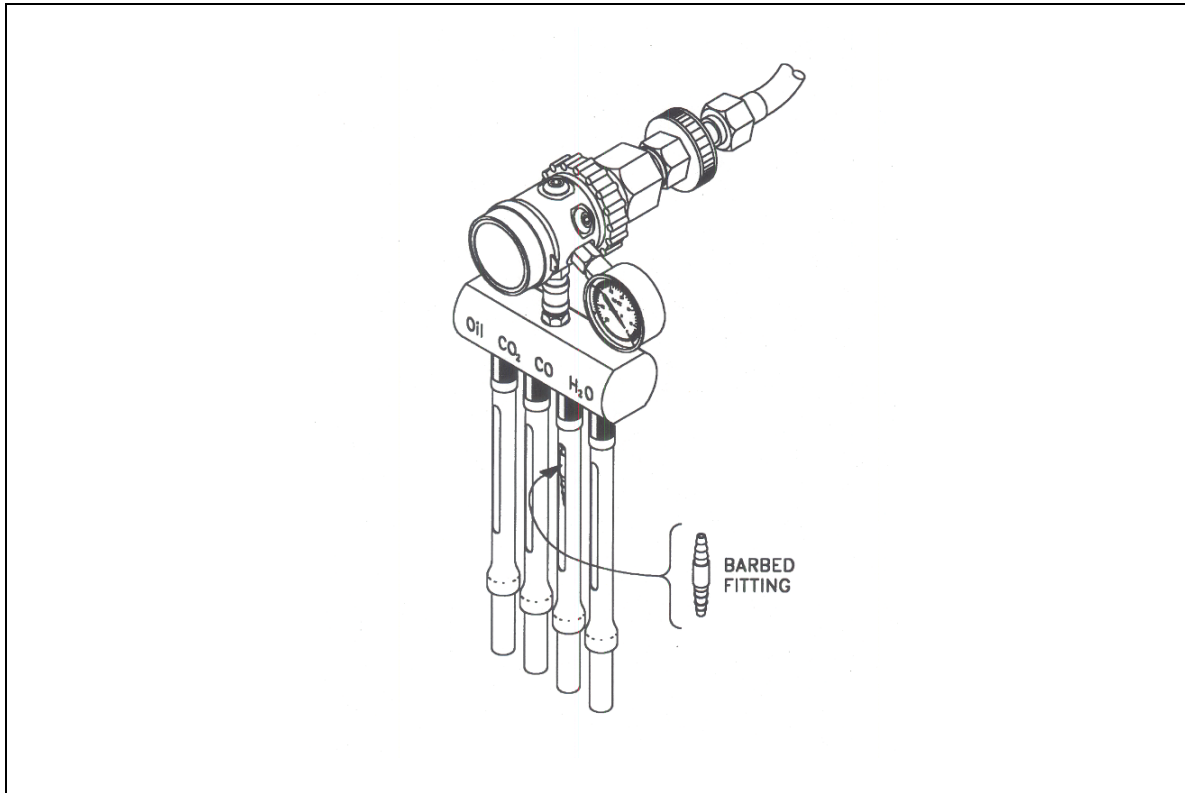

**Figure 4, Water Tube - Read only the reddish-brown level.**

E. To measure oxygen, insert the straight barbed fitting of Dräger breathing air test kit into CO tube holder as shown in Figure 5.

1. Ensure the breathing air source is open and sample air is flowing from measuring device.
2. Remove adapter (slip-on adapter for PHD Ultra or screw-on adapter for PHD6) from four-gas analyzer. Connect a short length of sampling tube between barbed

fitting and gas analyzer adapter as shown in Figure 6 (PHD Ultra) and Figure 7 (PHD Ultra or PHD6).



**Figure 5, O<sub>2</sub> Measuring Barbed Fitting Connection**

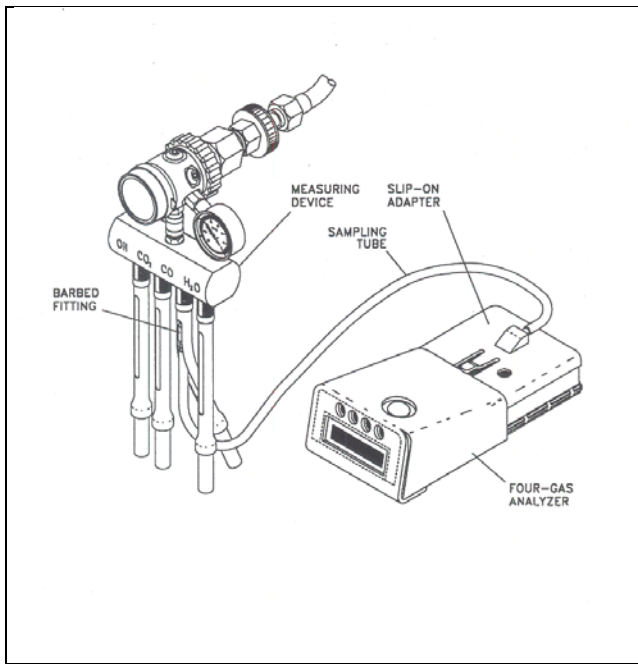

**Figure 6, PHD Ultra Four Gas Analyzer Connection to Air Test Kit**

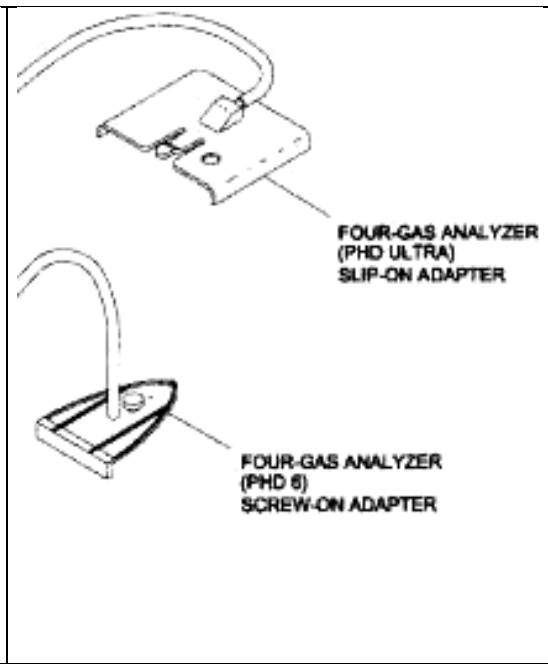

**Figure 7, Air Test Kit Connections to PHD Ultra or PHD6 Gas Analyzers**

3. Measure air sample for oxygen content as follows:
  - a. Turn analyzer on; after analyzer's automatic start up routine, read gas reading percentage displayed on screen.
  - b. Locate analyzer in an area of fresh air. Wait three minutes for gas readings to stabilize.
  - c. Press mode button three times within two seconds; Zero Calibration Mode screen should display. Within five seconds press mode button one time. Screen should display "Zero Calibration Please Wait," followed by "Zero Calibration Completed."
  - d. Wait 5 seconds; display should return to gas readings in percent.
  - e. Attach adapter (slip-on adapter for PHD Ultra or screw-on adapter for PHD6) to analyzer as shown in figure 6; and start electronic timer.
  - f. After one minute, read oxygen content from analyzer screen display. Reading should be greater than or equal to 19.5% and less than or equal to 23.5%.
- F. If measurements for water vapor, oil, carbon monoxide, carbon dioxide, or oxygen indicate an unsatisfactory result, any or all individual tests may be repeated.
- G. Secure breathing air source according to normal operating procedures and disconnect the PHD Ultra or PHD6 Gas Analyzer and breathing air test kit from the air source.
- H. Rinse the outlet end of each tube holder with clean fresh water. Cycle hand pump several times with discharge aimed into pail of water and dispose of water immediately.
- I. Thoroughly dry all air test kit components prior to stowage.
- J. Record test results on a Breathing Air Quality Report similar to the one shown below and maintain copies in a three ring binder. Also keep a log of maintenance, such as provided in Appendix D.



**COMPRESSOR  
BREATHING AIR QUALITY REPORT**

Compressor Model: \_\_\_\_\_

Date: \_\_\_\_\_

Serial No: \_\_\_\_\_

COMPONENT ANALYZED	SPECIFICATION FOR GAS	RESULTS
Oxygen	19.5 - 23.05 %	%
Carbon Dioxide	1000 ppm Max	ppm
Carbon Monoxide	10 ppm Max	ppm
Oil	<5 mg/m <sup>3</sup>	mg/m <sup>3</sup>
Water Vapor	18 mg/m <sup>3</sup> (24 ppm v/v)	mg/m <sup>3</sup> or ppm
	Or moisture content corresponding to the dew point at 1 atm. that is at least 10° F lower than the temperature in which the respirator will be worn	
Odor	Not Objectionable	

This is to certify that the above referenced sample DOES/DOES NOT meet the Grade D air purity standards for compressed breathing air per CGA G-7.1-2004.

Sample Taken By: \_\_\_\_\_

Next Sample Due on \_\_\_\_\_

## V. REFERENCES

---

1. OPNAVINST 5100.23 Series.

<http://doni.daps.dla.mil/Directives/05000%20General%20Management%20Security%20and%20Safety%20Services/05-100%20Safety%20and%20Occupational%20Health%20Services/5100.23G.pdf>

2. OPNAVINST 5100.19 Series.

<http://doni.daps.dla.mil/allinstructions.aspx?RootFolder=/Directives/05000%20General%20Management%20Security%20and%20Safety%20Services/05-100%20Safety%20and%20Occupational%20Health%20Services&View={1FF912B1-1BC6-444A-8943-B769C77880F2}>

3. Compressed Gas Association (CGA). CGA G-7.1-2011, Commodity Specification for Air. CGA, Arlington, VA. 2011.

